

NUMERICAL INVESTIGATIONS OF THE FORCED SPATIAL VIBRATIONS OF A WOOD SHAPER AND ITS SPINDLE, CAUSED BY UNBALANCE OF THE CUTTING TOOL

Georgi VUKOV

University of Forestry – Sofia, Faculty of Forest Industry
Blvd. Kliment Ohridski 10, 1797 Sofia, Bulgaria
Tel: 359 2 91907/285, E-mail: givukov@ltu.bg

Zhivko GOCHEV

University of Forestry – Sofia, Faculty of Forest Industry
Blvd. Kliment Ohridski 10, 1797 Sofia, Bulgaria
E-mail: zhivkog@ltu.bg

Valentin SLAVOV

University of Chemical Technology and Metallurgy – Sofia, Faculty of Metallurgy
Blvd. Kliment Ohridski 8, 1756 Sofia, Bulgaria
E-mail: valslav@abv.bg

Pavlin VICHEV

University of Forestry – Sofia, Faculty of Forest Industry
Blvd. Kliment Ohridski 10, 1797 Sofia, Bulgaria
E-mail: p_vitchev@abv.bg

Valentin ATANASOV

University of Forestry – Sofia, Faculty of Forest Industry
Blvd. Kliment Ohridski 10, 1797 Sofia, Bulgaria
E-mail: vatanasov_2000@yahoo.com

Abstract:

This study presents the results of the numerical investigations of the forced spatial vibrations of a wood shaper and its spindle, caused by unbalance of the cutting tool. The paper is based on a specific mechanical - mathematical model, developed by the authors, which allows studying of vibrations of this type of machinery. In this model a wood shaper and its spindle are regarded as rigid bodies, which are connected by elastic and damping elements with each other and with the motionless floor. This study renders an account the mass, inertia, elastic and damping properties and geometric parameters of the machine. The results of the numerical investigations are presented. They are obtained through modern software and by using parameters of a particular machine.

Key words: wood shapers; forced vibrations.

INTRODUCTION

Unbalance check of the spindle and cutting tool of the woodworking shaper machine is a compulsory stage of the preparation of the machine for its putting in action. Monitoring and timely detection of occurred unbalance during machine operation, largely determines the effectiveness of its work (Filipov 1977, Obreshkov 1996). The study of unbalanced forces on the spindle and cutting tool of the woodworking shaper machine is essential for its proper putting in action and as well as to guarantee its normal operation. The unbalanced inertia forces of the instrument cause significant additional dynamic loads on the spindle bearings, and consequently, on the whole construction (Grigorov 1985). The result of this additional load decreases significantly the operational resource of the machine. Sometimes this may even cause emergency stop of the machine for imperative repairs. This leads to serious losses from downtime due to unplanned required repairs. Another possible result of the rising of the significant unbalanced inertia forces of the cutting tool of the machine is a violation of the accuracy and quality of its products.

The analysis of the unbalance influence of the cutting tool on the machine operation requires carrying out specific studies. The machine can be seen as a mechanical vibrating system with known characteristics in these researches (Amirouche 2006, Coutinho 2010). Furthermore, it is necessary to apply modern methods for studying of dynamic systems. The majority of modern methods for the study of dynamic systems are oriented towards the use of computing technique, which allows obtaining the final results of the study in numerical form (Angelov and Slavov 2010). The solving a practical problem cannot be achieved directly by applying one or several numerical methods. It is usually too long and complicated to deal with the

problem as it starts with putting the problem for solving and finishes with obtaining the final results of the calculations, which are applicable in practical implementation. Series of numerical investigations, measurements and experiments must be conducted, systematized and worked up. These investigations are based on specifically developed model of the studied machine.

Some different mathematical models of the studied machinery can be built for the same solved problems. They have to reflect as accurately as possible the character and manner of operation of the researched object. The choice of model depends on the specific tasks of the study. Appropriate numerical method can be applied just after analyzing all data output and choosing a suitable mathematical model. Each numerical method that associates the mathematical model with a numerical algorithm guarantees a certain accuracy of the results. These results are the primary database for solving the practical problems. All this refers to the research of work of the wood shaper machine and it is reflected in previous works of authors (Vukov et al. 2016).

OBJECTIVE

The objective of this study is to conduct numerical investigations of the forced spatial vibrations of a wood shaper machine and its spindle, caused by unbalance of the cutting tool. The model refers to wood shapers with lower placement of the spindle. The obtained results are illustrated graphically in order to be analyzed more easily. The investigations are done on the basis of the developed by the authors concrete mechanic - mathematical model for the study of forced spatial vibrations of these types of wood shapers. The model is presented in the previous part of this work. The model renders in account the construction's characteristics of this class of wood shapers. The wood shaper and its spindle are regarded as rigid bodies, which are connected by elastic and damping elements with each other and with the motionless floor. These elastic and damping elements are four vibration isolators between the machine and the floor, and the two bearing units of the spindle. Static imbalance of the cutting tool is modelled. The calculations use the parameters of a real wood shaper.

MATERIAL, METHOD, EQUIPMENT

The first part of this study presents a built-up by the authors dynamic model of the machine. It gives a system matrix differential equations and appropriate analytical solutions. The numerical solutions which are obtained on their base are submitted in this part of the work. Parameters of the machine FD-3, produced in ZDM – Plovdiv, Bulgaria and put into practice, are used. These parameters are presented below.

The two bodies and the whole machine are modelled by software Solid Works in this part of the study. These models are shown respectively in Fig. 1, Fig. 2 and Fig. 3. The mass centre of the body 1 coincides with the centre of the local coordinate system of the body 1 and the centre of the reference coordinate system. The mass centre of the body 2 coincides with the centre of the local coordinate system of the body 2.

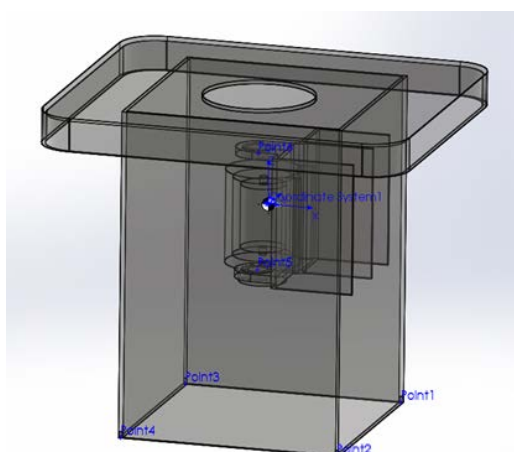

Fig. 1.
Body 1.



Fig. 2.
Body 2.

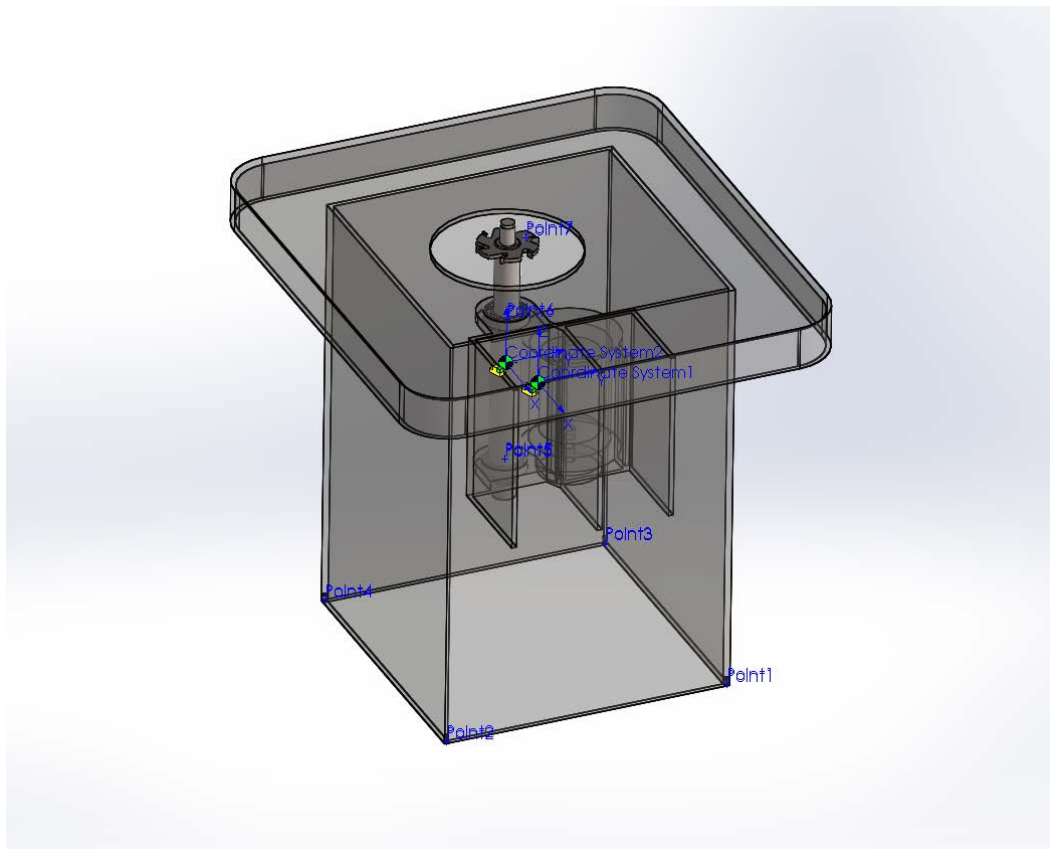

Fig. 3.
Wood shaper.

The presented data below are used for the calculations. They are of the real machine FD-3 which is often used in practice.

Mass of the body 1 – $m_1 = 303,43\text{kg}$; the body mass 2 – $m_2 = 11,12\text{kg}$. Tensor of mass inertia moments of the body 1 relative to the local coordinate system of the body 1, $\text{kg}\cdot\text{m}^2$

$$M1=303.43; M2=11.12;$$

$$I_1 = \begin{bmatrix} 37,2215 & -0,1064 & -0,0566 \\ -0,1064 & 38,6641 & -0,1915 \\ -0,0566 & -0,1915 & 34,8599 \end{bmatrix}$$

Tensor of mass inertia moments of the body 2 relative to the local coordinate system of the body 2, $\text{kg}\cdot\text{m}^2$

$$I_2 = \begin{bmatrix} 0,2937 & 0 & 0 \\ 0 & 0,2937 & 0 \\ 0 & 0 & 0,0052 \end{bmatrix}$$

$$J1xx=37.2215; J1yy=38.6641; J1zz=34.8599;$$

$$J1xy=0.1064; J1xz=0.0566; J1yz=0.1915;$$

$$J2xx=0.2937; J2yy=0.2937; J2zz=0.0052; J2xy=J2xz=J2yz=0;$$

Coordinates of the pivot points of the body 1 to the centre of the coordinate system of the body 1, m:

p.1	p.2	p.3	p.4
$x = 0,287$	$x = 0,287$	$x = -0,303$	$x = -0,303$
$y = 0,279$	$y = -0,311$	$y = 0,279$	$y = -0,311$
$z = -0,579$	$z = -0,579$	$z = -0,579$	$z = -0,579$

Coordinates of the pivot points of the body 2 to the centre of the coordinate system of the body 1, m:

$$\begin{array}{ll} p.5 & p.6 \\ x = -0,008 & x = -0,008 \\ y = -0,066 & y = -0,066 \\ z = -0,160 & z = 0,151 \end{array}$$

Coordinates of the pivot points of the body 2 to the centre of the coordinate system of the body 2, m:

$$\begin{array}{ll} p.5 & p.6 \\ x = 0 & x = 0 \\ y = 0 & y = 0 \\ z = -0,214 & z = 0,096 \end{array}$$

Elasticity coefficients, N/m

$$\begin{array}{l} cx011=cx012=cx013=cx014=350000; \\ cy011=cy012=cy013=cy014=350000; \\ cz011=cz012=cz013=cz014=800000; \\ cx125=cx126=1500000; \\ cy125=cy126=2250000; \\ cz125=4500000; cz126=0; \end{array}$$

Damping coefficients, (N.s)/m

$$\begin{array}{l} bx011=bx012=bx013=bx014=980; \\ by011=by012=by013=by014=670; \\ bz011=bz012=bz013=bz014=470; \\ bx125=bx126=980; \\ by125=by126=670; \\ bz125=470; bz126=0; \end{array}$$

Coordinates of the application point of the force of the unbalance (p. 7) in the coordinate system of the body 2

$$r_F = \begin{bmatrix} I_{Fx} \\ I_{Fy} \\ I_{Fz} \end{bmatrix} = \begin{bmatrix} -0,018 \\ 0,046 \\ 0,258 \end{bmatrix}$$

RESULTS AND DISCUSSION

Calculations have been made for three different values of the angular velocity of the spindle – $66s^{-1}$, $100s^{-1}$ and $133s^{-1}$ and at three values of the unbalance – $0.010kg.m$, $0.015kg.m$ and $0.020kg.m$. Just a few of the results are represented here due to the limited place. The results illustrating vibrations of the machine body (coordinate q_1), as well as those of the cutter (coordinate q_7), are presented below. Fig. 4 shows the result for these coordinates when the unbalance is $0.010kg.m$ for the three angular velocities of the spindle ($66s^{-1}$, $100s^{-1}$ and $133s^{-1}$). Fig. 5 shows the results at unbalance $0.015kg.m$ for the same three angular speeds of the spindle, and fig. 6 - at unbalance of $0.020kg.m$.

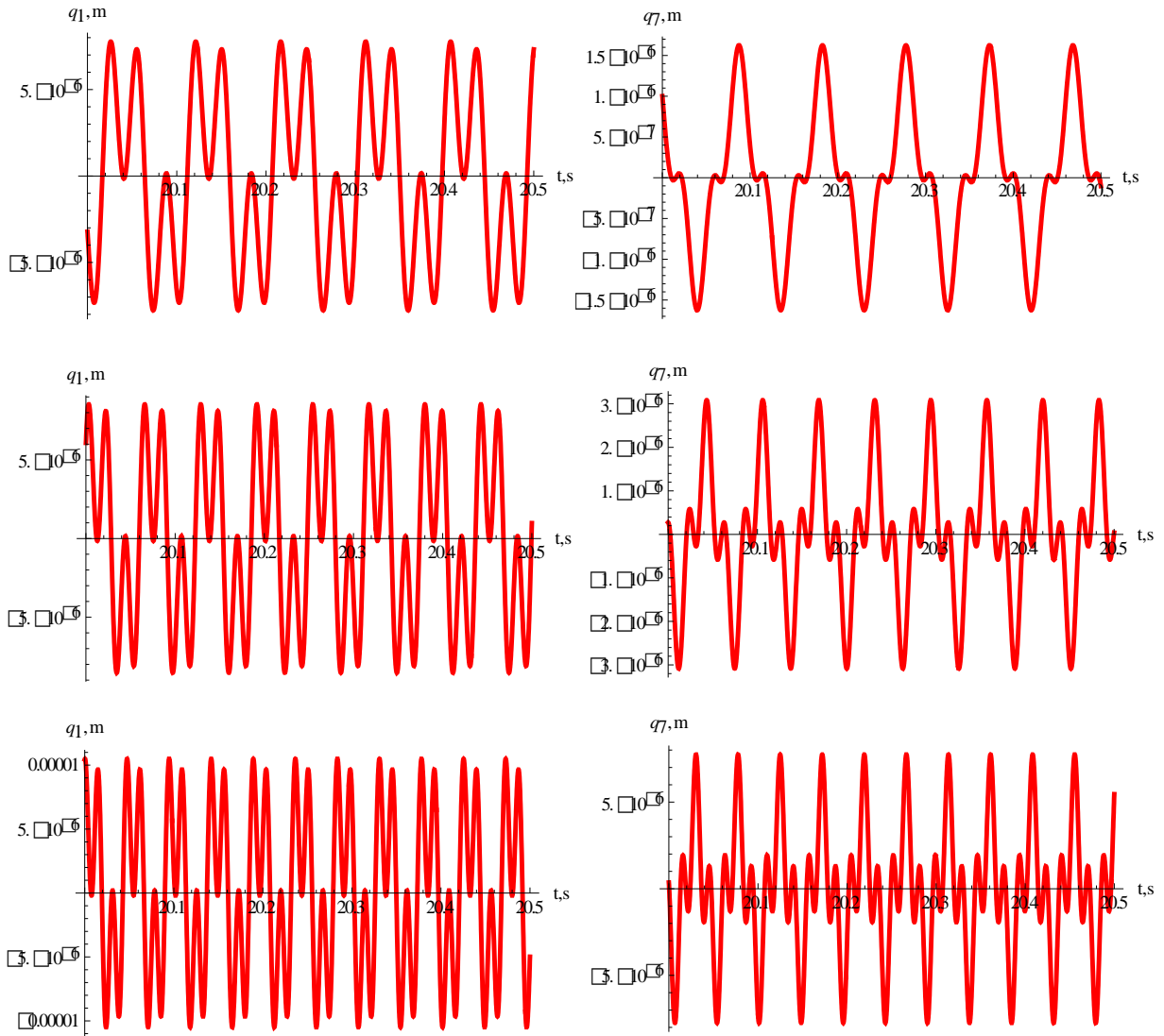

Fig. 4.
Results unbalance 0.010kg.m.

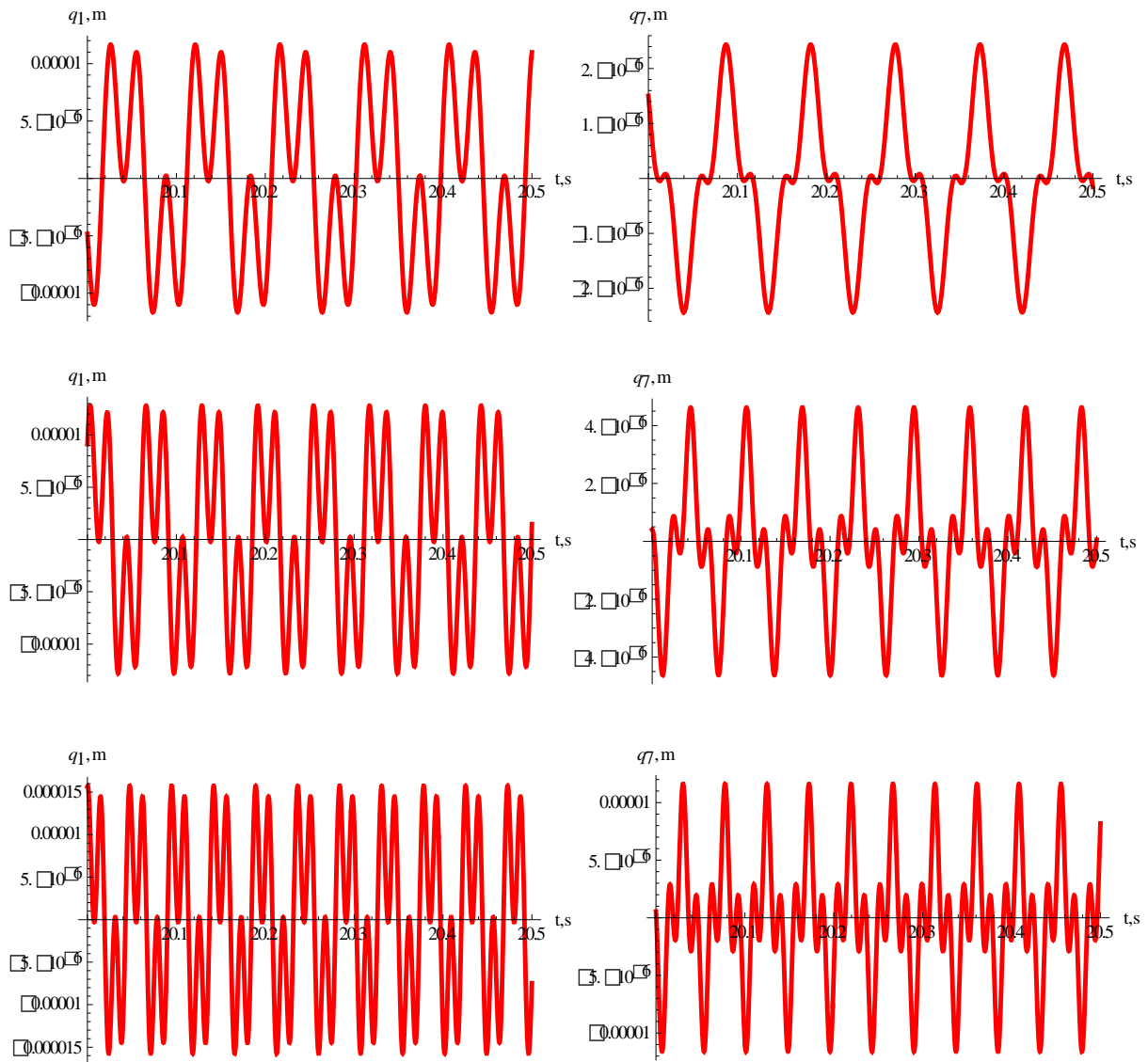

Fig. 5.
Results unbalance 0.015kg.m.

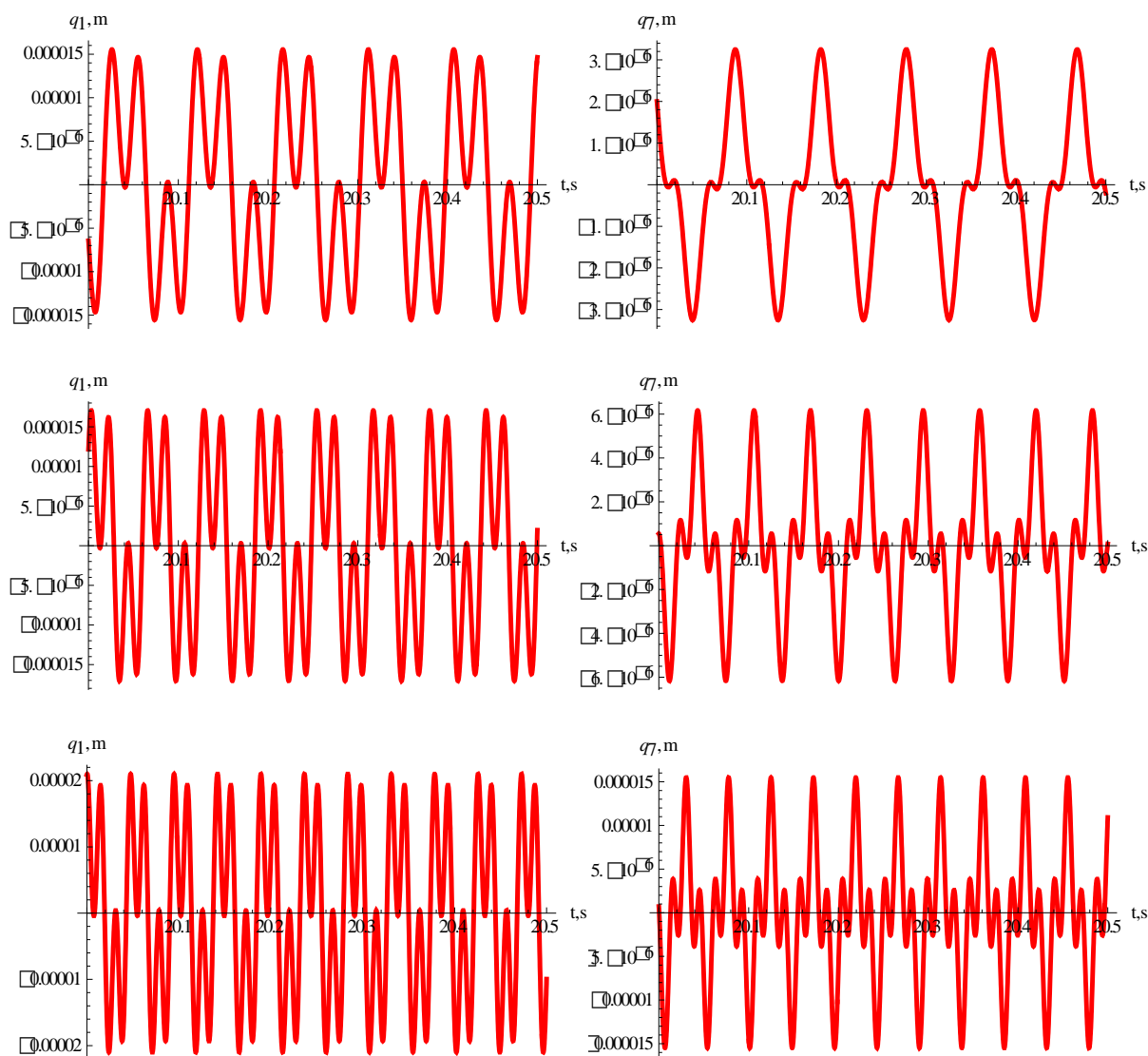

Fig. 6.
Results unbalance 0.020kg.m.

The analysis of the obtained results shows that presence of unbalance of the cutting tool of wood shaper generates intense spatial vibrations not only on the spindle, but on the whole machine. The amplitude of these vibrations increases greatly along with the increase of the value of unbalance and angular speed of the spindle. The specific values depend on the machine parameters and conditions of its work. It confirms the need for precise pre-balancing of the cutting tool, which is especially important in fast moving wood shapers. The results verify the applicability of the model developed by the authors for studying the vibration behavior of wood shapers.

CONCLUSIONS

The presented study investigates and illustrates the forced spatial vibrations of a wood shaper and its spindle, caused by unbalance of the cutting tool. The study is made numerically by using a modern software product. The calculations are performed on the base of a specific mechanical - mathematical model, which allows studying of vibrations of this type of machinery. The advantages of the model are in the consideration of the characteristics in the construction of these kinds of wood shapers. The model also includes parameters of elastic and damping elements of the structure. Numerical investigations are carried out by using the parameters of a real machine. The results of the conducted investigations allow analyzing the influence of static unbalance of the cutting tool on the vibration behavior of this machine. Raising of the reliability of the machine as well as the accuracy and quality of processing products is the final goal, which is meant.

ACKNOWLEDGEMENT

This work has been supported by the Scientific Research Sector at the University of Forestry – Sofia, Bulgaria under contract № 22/19.01.2016.

REFERENCES

- Amirouche F (2006) Fundamentals of Multibody Dynamics – Theory and Applications, Birkhäuser, Boston.
- Angelov I, Slavov V (2010) Book of problems. Matrix mechanics – Dynamics (in Bulgarian), Avangard Prima, Sofia.
- Coutinho M (2010) Dynamic Simulations of Multibody Systems, Springer-Verlag, New-York.
- Filipov G (1977) Woodworking machines (in Bulgarian). Technics. Sofia.
- Grigorov P (1985) Cutting of wood (in Bulgarian). Technics. Sofia.
- Obreshkov P (1996) Woodworking machines (in Bulgarian). Technics. Sofia.
- Vukov G, Gochev Zh, Slavov V, Vichev P, Atanasov V (2016) Mechanic-Mathematical Model for Investigations of the Natural Frequencies and Mode Shapes of the Free Spatial Vibrations of Wood Shaper and its Spindle, Proceedings of the 10th International Science Conference „Chip and Chipless Woodworking Processes”, Slovakia, Technical University in Zvolen, 10(1):203 – 209.
- Vukov G, Gochev Zh, Slavov V, Vichev P, Atanasov V (2016) Numerical Investigations of the Natural Frequencies and Mode Shapes of the Free Spatial Vibrations of Wood Shaper and its Spindle, Proceedings of the 10th International Science Conference „Chip and Chipless Woodworking Processes”, Slovakia, Technical University in Zvolen, 10(1):211 – 216.
- Vukov G, Gochev Zh, Slavov V (2016) Mechanic-Mathematical Model for Investigations of the Free Damped Spatial Vibrations of Wood Shaper and its Spindle, Proceedings of the IInd International Furniture Congress, Mugla, Turkey, October 13th-15th, 216 – 219.
- Vukov G, Gochev Zh, Slavov V (2016) Numerical Investigations of the Free Damped Spatial Vibrations of Wood Shaper and its Spindle, Proceedings of the IInd International Furniture Congress, Mugla, Turkey, October 13th-15th, 220 – 224.